

NJTA LOAD CENTER TYPE F AND FOUNDATION

NOTES

- ALL INTERCONNECTIONS BETWEEN DEVICES SHALL BE BY MEANS OF OPEN WIRING PROPERLY FASTENED TO BACK BOARD WITH APPROVED INSULATED TYPE CLAMP ASSEMBLY.
- FOR SERVICE RUN LONGER THAN 300 FEET, WIRE SIZE SHALL BE AS PER THE CONTRACT DRAWINGS.
- THE CONTRACTOR SHALL SUBMIT FOR APPROVAL A DETAILED LAYOUT OF ALL INTERNAL DEVICES, BASED ON THE ACTUAL DIMENSIONS OF PROPOSED EQUIPMENT AND ENCLOSURES.
- THE CONTRACTOR SHALL SUPPLY AND INSTALL A LOAD CENTER AND A METER CABINET. THE LOAD CENTER SHALL BE DOUBLE DOOR, WITH RISER BASE (15"Hx72"Wx24"D) AND ALUMINUM BACK PANEL, NEMA 3R RATED AND MADE FROM 0.125" ALUMINUM (5052-H32). LOAD CENTER SHALL HAVE SLAM LOCK WITH CORBIN #2 KEY. METER CABINET SHALL HAVE BLACK PLYWOOD BACK PANEL AND "POLICE SLAM LATCH" WITH SKELETON KEY. CONTRACTOR SHALL PROVIDE MANUFACTURER'S SHOP DRAWING FOR THE CABINETS TO THE ENGINEER FOR APPROVAL.
- PROVIDE GROUND ROD (3/4"X10FT LONG) AT ALL CABINETS AND TYPE-C JUNCTION BOX. GROUND ROD SHALL BE INSTALLED AND BONDED TO THE FOUNDATION REBAR, COORDINATED WITH THE PAD POUR; IT SHALL BE STUBBED-UP 4" IN THE BOTTOM OF THE CABINETS FOR CONNECTION. SEE SPECIFICATIONS IN SECTION 918.
- MAINTENANCE PAD SHALL HAVE A LOW-DEGREE SLOPE AWAY FROM THE LOAD CENTER CABINET FOUNDATION.
- 0.025 GAUGE ALUMINUM NAMEPLATE WITH DIE STAMPED BLACK LETTERS AND NUMBERS SHALL BE INSTALLED ON EACH CABINET DOOR. NAMEPLATE SHALL HAVE STAINLESS STEEL RIVET TYPE SCREW TO MOUNT IT ON THE CABINET. INSTALL NAMEPLATE 8" BELOW TOP OF CABINET.
- LOCATION OF MTS AND METER CABINET FOUNDATION, SIZE, NUMBER AND DIRECTION OF CONDUIT RUN SHALL BE TAKEN FROM THE CONTRACT ELECTRICAL PLANS FOR THE AREA WHERE REQUIRED AND SUBJECT TO THE APPROVAL OF THE ENGINEER.
- TERMINATE ALL METAL CONDUITS WHEN ENTERING ENCLOSURES WITH LOCKNUT AND BONDING BUSHINGS. ALL OTHER CONDUITS SHALL BE PROVIDED WITH BONDING BUSHINGS.
- THE CONTRACTOR SHALL SUBMIT A REINFORCING STEEL DESIGN LAYOUT FOR THE CABINETS FOUNDATION AS PART OF THE SHOP DRAWING SUBMISSION FOR APPROVAL BY ENGINEER.
- ANCHORAGE OF CABINET ENCLOSURE SHALL BE AS PER CABINET MANUFACTURER'S DETAILS.
- THE CONTRACTOR SHALL LABEL ALL EQUIPMENTS WITH VOLTAGE AND THEIR USE. (I.E. 480/277V, 3-PHASE, LP ETC.)
- CONTRACTOR SHALL EXTEND FOUR (4) 3" RIGID METALLIC CONDUITS TO THE TYPE C JUNCTION BOX AND THE REMAINING FOUR (4) 3" CONDUITS SHALL BE EXTENDED 18" BEYOND THE CONCRETE SLAB AND KEPT AS SPARES FOR FUTURE USE. SPARE CONDUITS SHALL BE CAPPED IN THE GROUND.
- THE CONDUIT CONFIGURATION SHOWN IS FOR ONE OR TWO TYPE C JUNCTION BOXES. IF A MANHOLE IS SPECIFIED IN THE CONTRACT PLANS, THE CONTRACTOR SHALL INSTALL TWO (2) ROWS OF 4 CONDUITS INSTEAD OF EIGHT (8) CONDUITS ACROSS.
- SEE E-33 FOR THE LOAD CENTER WIRING DIAGRAM.
- COLD SEQUENCE SHOWN FOR THE SAFETY SWITCH WITH "LOCK ON" OPTION BEFORE THE METER FOR 480V SERVICE. CONTRACTOR SHALL COORDINATE THE REQUIREMENTS OF COLD SEQUENCE VS HOT SEQUENCE WITH THE UTILITY COMPANY AND SHALL ADJUST LOCATION OF THE SAFETY SWITCH ACCORDINGLY. LABEL SWITCH "480 VOLT METER DISCONNECT". CONDUITS, CONDUIT FITTINGS, AND COUPLINGS SHOULD NOT INTERFERE WITH DISCONNECT SWITCH ENCLOSURE DOOR.
- CONSTRUCT THE MAINTENANCE PAD WITH AN EXPANSION JOINT IN-LINE WITH THE POINT WHERE THE PAD MAKES A 90° BEND AROUND THE LOAD CENTER FOUNDATION.
- ALL OPEN CONDUIT TERMINATIONS SHALL HAVE RODENT BLOCKING MATERIAL INSTALLED. SEE DETAILS ON STANDARD DRAWING E-16.

LEGEND:

- (A) METER SOCKET AND METER: METER SOCKET SHALL BE FURNISHED AND INSTALLED BY THE CONTRACTOR AS APPROVED BY THE UTILITY COMPANY. METER SHALL BE FURNISHED AND INSTALLED BY THE UTILITY COMPANY. (METER SHALL BE SIZED FOR 480V, 3φ, 200A SERVICE).
- (B) MAIN CIRCUIT BREAKER: 480V, 3-PHASE, MOLDED CASE CIRCUIT BREAKER LABELED "MAIN". CIRCUIT BREAKER AND ENCLOSURE SHALL BE AS SHOWN BELOW, SIZE AS PER CONTRACT PLANS. AIC RATING MAY DEPEND ON RATING FROM THE UTILITY AND THE CALCULATED ASYMMETRICAL FAULT CURRENT.
100A FRAME, 100A TRIP, 18K A.I.C. 250A FRAME, 200A TRIP, 35K A.I.C.
- (C) MAIN CONTACTOR: 3-POLE, 480V, 100A FRAME, ELECTRICALLY HELD CONTACTOR WITH 120V COIL, WITHOUT ENCLOSURE.
- (D) CONTROL TRANSFORMER: 480V - 120/240V, 1-PHASE, 3 WIRES, 3KVA DRY TYPE TRANSFORMER WITH MOUNTING LUGS FOR OUTDOOR USE.
- (E) CONTROL CIRCUIT BREAKER: 2-POLE, 480V, 100A FRAME, 15A TRIP, BOLT ON TYPE CIRCUIT BREAKER WITHOUT ENCLOSURE.
- (F) CONTROL PANELBOARD: 1-PHASE, 3 WIRES, 120/240V, 100A MAINS WITH (12) 1-POLE SPACES, WITH SOLID GROUNDABLE NEUTRAL, WITH ENCLOSURE.
- (G) LIGHTING PANELBOARD: 480V, 3-PHASE, 4 WIRES, 480Y/277V, 100A BUSS, MAIN LUG ONLY, SOLID GROUNDABLE NEUTRAL AND (30) 1-POLE SPACES WITHOUT ENCLOSURE. PANELBOARD SHALL BE NEMA 3R. CIRCUIT BREAKERS SHALL BE THE FOLLOWING RATINGS, AS SPECIFIED IN THE CONTRACT PLANS.
1-POLE-30A 1-POLE-50A
- (H) BYPASS SWITCH: SPST, 20A, 120V, HEAVY DUTY TOGGLE SWITCH IN WEATHER PROOF TYPE-FS BOX.
- (I) PHOTOCELL UNIT: SINGLE POLE, 120V, 1800W WITH RECEPTACLE MOUNTING BRACKET AND 18" LEADS. PHOTOCELL SHALL BE MOUNTED THRU CONTROL CABINET (120V) WITH GASKETED LEXAN LENS FACING NORTH AND SHALL NOT BE AFFECTED BY ARTIFICIAL LIGHTS.
- (J) THERMOSTAT: 240V FRAME, 120V LINE, 500W, 40°F TO 70°F OPERATING RANGE, WEATHER PROOF TYPE-FS BOX.
- (K) STRIP HEATER: 120V, 500W, CHROME STEEL SHEATH FOR TEMPERATURES UP TO 1200°F (MAX), 1 1/2" WIDE TERMINALS AT ONE END.
- (L) DUPLEX RECEPTACLE: 120V, 20A HEAVY DUTY DUPLEX RECEPTACLE GFCI TYPE WITH GROUNDING LUG IN WEATHER PROOF TYPE-FS BOX AND SHALL BE ATTACHED TO BOTTOM OF 120V PANEL.
- (M) SECONDARY CIRCUIT BREAKER: 3-PHASE, 480V, 18K A.I.C., 100A FRAME, 100A TRIP, WITHOUT ENCLOSURE.
- (N) COPPER GROUND ROD: 3/4" DIA. X 10FT LONG. SEE NOTE 5.
- (O) ANCHOR BOLT ASSEMBLY: (SEE E-33)
- (P) COPPER GROUND LUG: 3/8" BOLTS SIZE, #8 AWG GROUND WIRE, TIN PLATED WITH INSPECTION HOLE, LUG SHALL HAVE RED COLOR DYE.
- (Q) METER DISCONNECT: 480V, 3-WIRE, SINGLE THROW, NON-FUSIBLE SAFETY SWITCH WITH LOCK ON OPTION. SWITCH SHALL BE INSTALLED INSIDE STAINLESS STEEL NEMA 4X ENCLOSURE. SWITCH AND ENCLOSURE SHALL BE AS SHOWN BELOW, SIZE AS PER CONTRACT PLANS.
100A SERVICE 200A SERVICE
- (R) SURGE PROTECTIVE DEVICE: 240V/480V 50KV PER PHASE SURGE PROTECTIVE DEVICE.
- (S) POWER DISTRIBUTION BLOCKS: NEUTRAL AND THREE PHASES, PRE-WIRED FROM LOAD SIDE OF BREAKERS TO TOP SIDE OF BLOCKS.
- (T) UTILITY BREAKER: 200A 3-POLE CIRCUIT BREAKER LABELED "UTILITY", 80% RATED 35KAIC AT 480VAC
- (U) GENERATOR BREAKER: 200A 3-POLE CIRCUIT BREAKER LABELED "GENERATOR", 80% RATED 35KAIC AT 480VAC
- (V) SINGLE POLE RECEPTACLES: 200A CAM-TYPE SINGLE POLE MALE RECEPTACLES. GENERATOR FEMALE PLUGS NOT INCLUDED AND SHALL BE ORDERED AS A SEPARATE ACCESSORY WHEN REQUIRED.
- (1) EIGHT (8) 3" RIGID METALLIC CONDUIT WITH BRONZE GROUND BUSHINGS, COUPLINGS AND EXTENSION CONDUIT STUBS, AS REQUIRED. SEE NOTE 13.
- (2) 3" RIGID METALLIC CONDUIT (INCOMING SERVICE) SHALL HAVE 4 #2 AWG WIRES. CONTRACTOR SHALL LEAVE WIRE COIL 10 FT. UP THE POLE FOR UTILITY CONNECTION AND SHALL SEAL TOP OF CONDUIT ON THE POLE. SEE NOTE 2.
- (3) 3" PVC SCH-40. (NOMAL POWER TO MANUAL TRANSFER SWITCH)
- (4) GROUND WIRE TO THE RIGID METALLIC BRONZE CONDUIT BUSHING, CABINET AND GROUND ROD W/APPROVED CONNECTOR. #8 AWG BARE GROUND WIRE FOR UNDERGROUND SERVICE ENTRANCE CONDUCTOR SIZE #2 OR SMALLER. FOR UNGROUNDED SERVICE CONDUCTORS LARGER THAN #2 AWG, GROUNDING CONDUCTOR SIZE SHALL BE SIZED PER NEC.
- (5) 3" RIGID METALLIC CONDUIT WITH INCOMING SERVICE WIRES.
- (6) 2" RIGID METALLIC CONDUIT WITH 4 #2 AWG.
- (7) 3" LIQUIDTITE FLEX METALLIC CONDUIT (LFMC) WITH 4 #2 AWG OR AS SPECIFIED ON THE CONTRACT PLANS. (TO LOAD CENTER)
- (8) 3" RIGID METALLIC CONDUIT WITH BRONZE GROUND BUSHINGS, COUPLINGS AND EXTENSION CONDUIT STUBS, AS REQUIRED TO TRANSFER SWITCH AND GENERATOR DOCKING STATION.

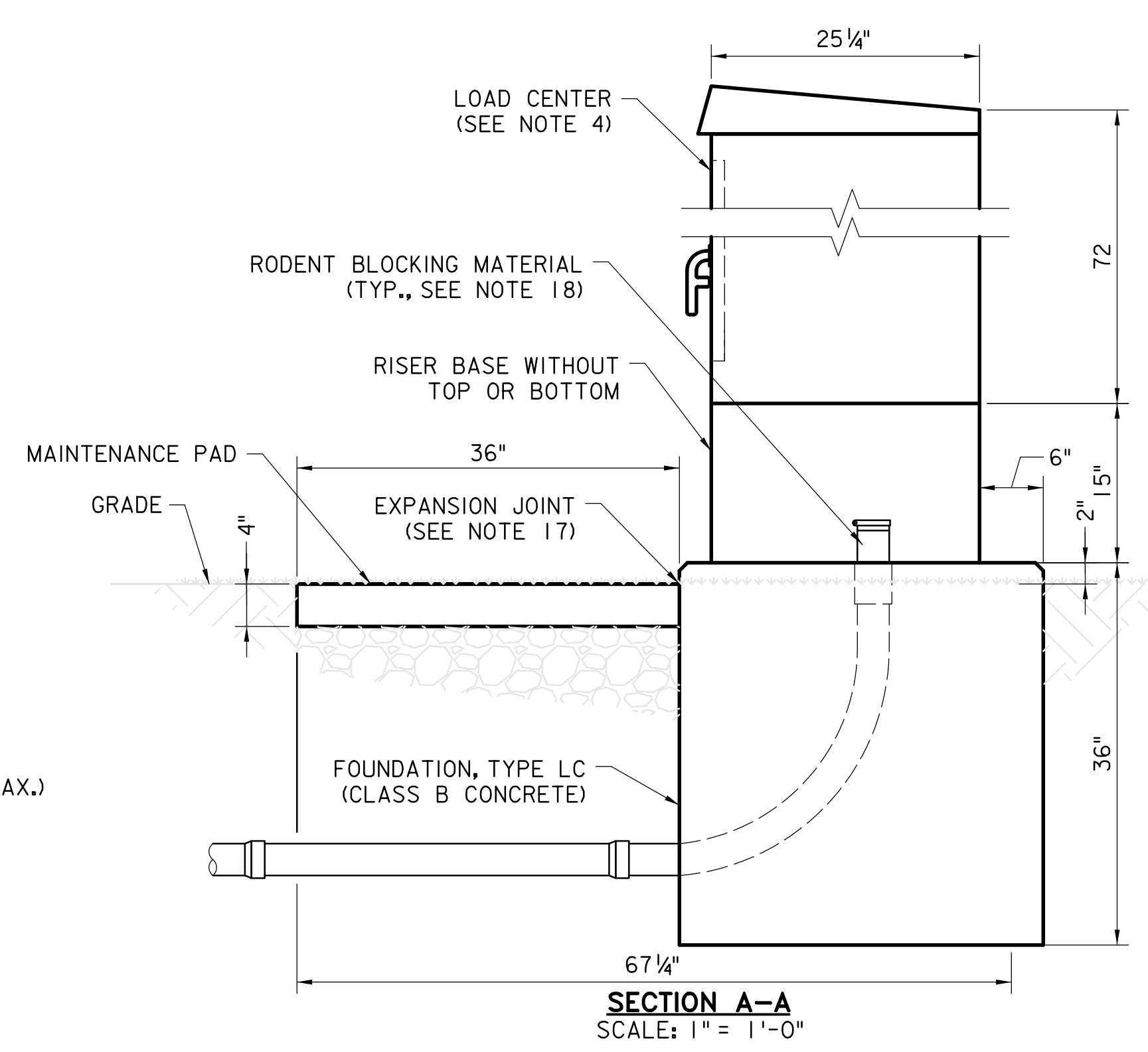

CABINET LABEL NOTE:
SEE STD. DWG. E-16 FOR NAMEPLATE DETAILS.
NAMEPLATE MOUNTED ON THE CABINET DOOR SHALL HAVE INFORMATION AS SHOWN BELOW:
METER CABINET
480/240/208V, (1-PHASE OR 3-PHASE)
NJ TURNPIKE/GSP
EMERGENCY CONTACT: TP OPERATIONS 800-352-4848
METER CABINET NAME: UTILITY BUILDING DESIGNATION (E.G. SA11N) OR MILEPOST (E.G. MP112.3)

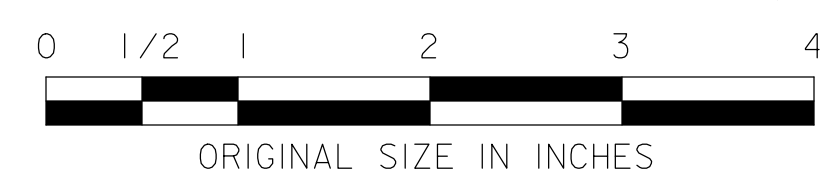

| | |
|--|---------------------------------|
| NEW JERSEY TURNPIKE AUTHORITY NEW JERSEY TURNPIKE GARDEN STATE PARKWAY | |
| STANDARD DRAWINGS | |
| TYPE F LOAD CENTER DETAILS - 1 | |
| OFFICE OF THE CHIEF ENGINEER NEW JERSEY TURNPIKE AUTHORITY WOODBRIIDGE, NEW JERSEY | STANDARD DRAWING E-32 |

| REV. | DESCRIPTION | DATE |
|------|------------------|-------|
| 0 | REISSUED DRAWING | 09/21 |