

D(NJTA)10-1a

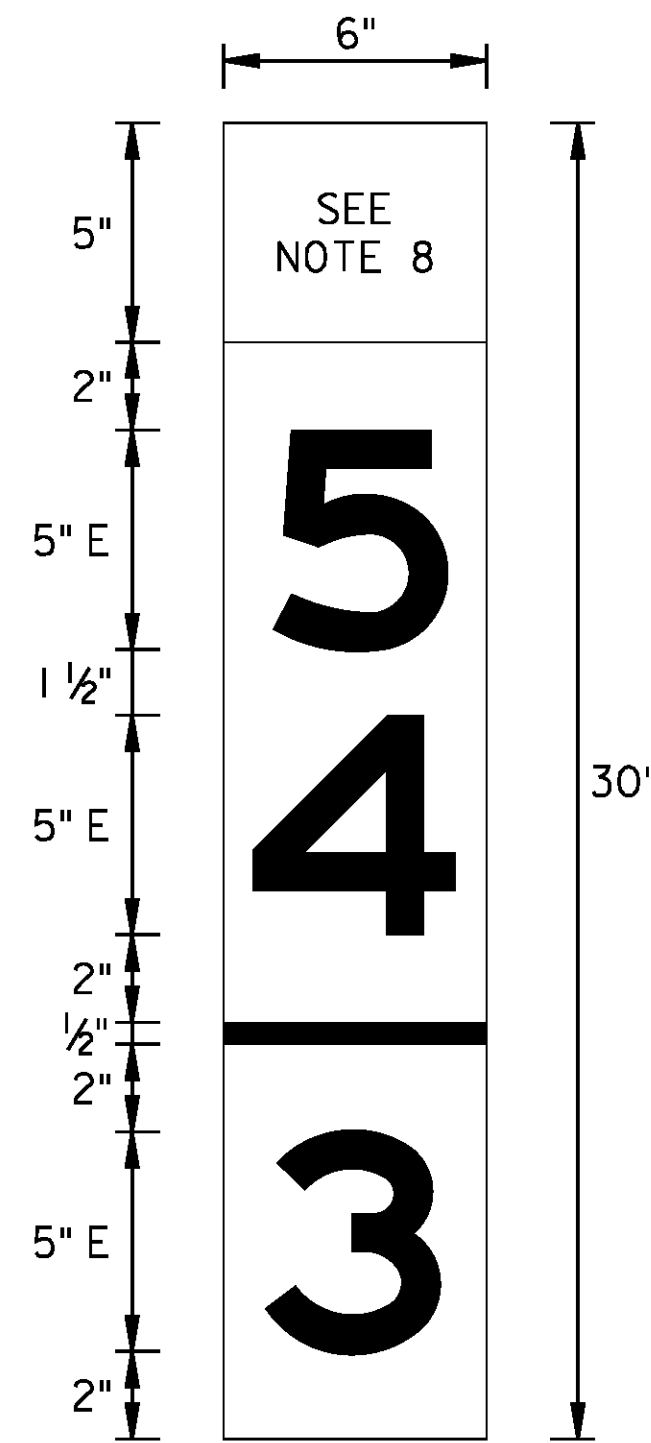

D(NJTA)10-2a  
SEE NOTE 5

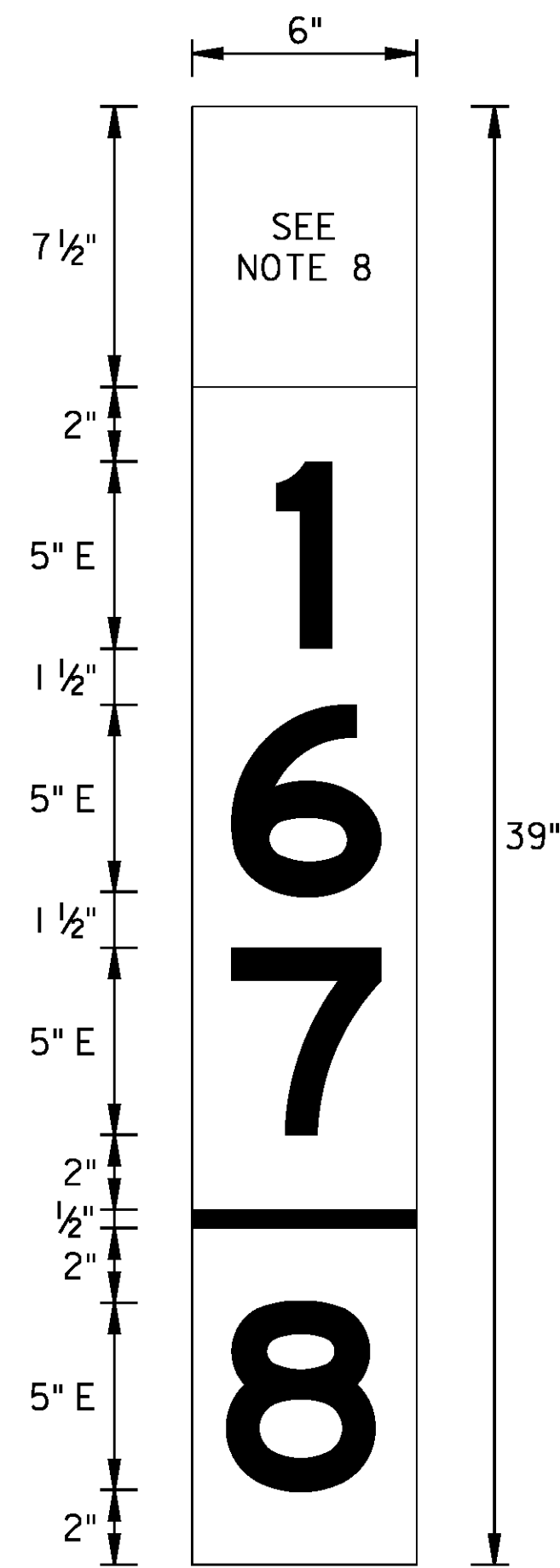

D(NJTA)10-3a

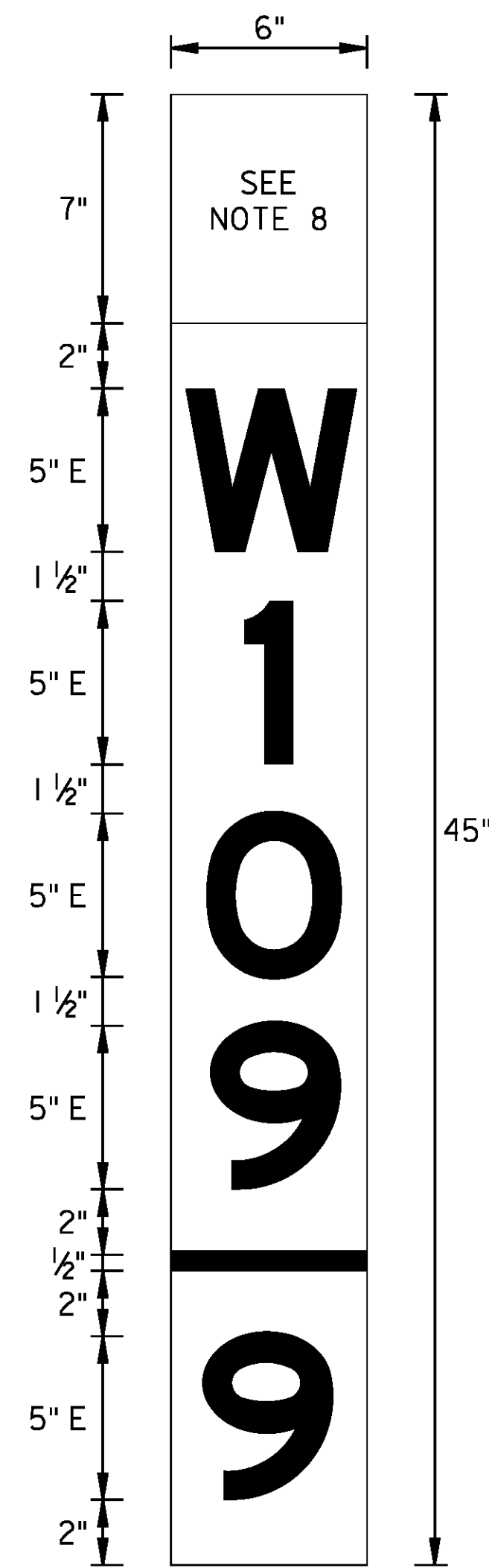

D(NJTA)10-4a  
SEE NOTE 6

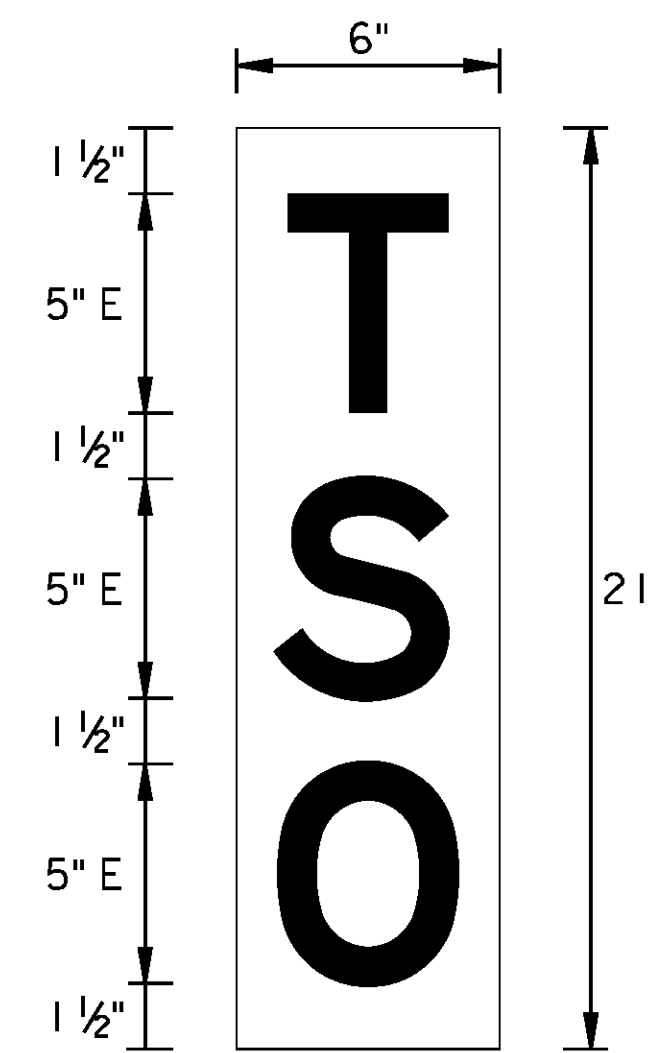
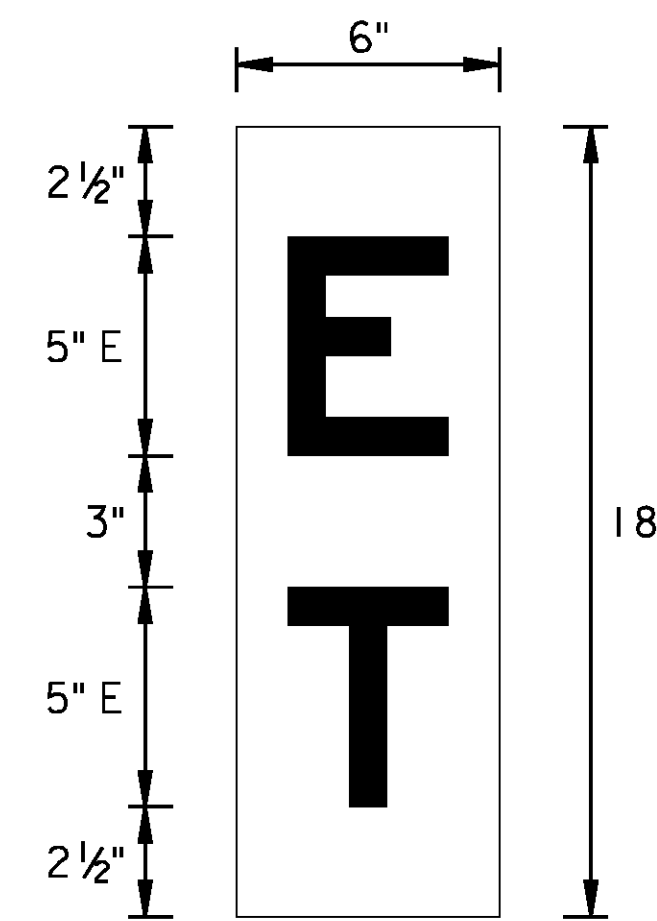

RAMP IDENTIFIERS  
SEE NOTE 7

NO BORDER NO RADIUS  
LEGEND AND DIVIDER: WHITE  
BACKGROUND: GREEN  
SEE NOTE 3

**NOTES:**

- SEE STANDARD DRAWING DE-3 FOR TENTH-MILE MARKER MOUNTING DETAILS. SEE STANDARD DRAWING SL-6 FOR MORE INFORMATION.
- OPTICALLY BALANCE ALL CHARACTERS ABOUT THE VERTICAL AXIS.
- TENTH-MILE MARKERS ARE ONLY TO BE USED FOR PARTIAL MILEPOSTS. THESE SIGNS ARE NOT TO BE USED FOR INTEGER MILEPOSTS.
- STRUCTURE IDENTIFIERS DETAIL (D(NJTA)10-7 SERIES) ONLY TO BE USED BY AUTHORITY FORCES. STRUCTURE IDENTIFIERS ARE MOUNTED TO BRIDGE PIERS (OVERCROSSINGS) AND PARAPETS (UNDERCROSSINGS). IF NECESSARY, PUNCTUATION IS PERMITTED ON THESE SIGNS.
- FOR THE NEW JERSEY TURNPIKE, THE D(NJTA)10-2a SIGN IS TO BE IMPLEMENTED ON BOTH THE NEWARK BAY - HUDSON COUNTY EXTENSION AND THE PEARL HARBOR MEMORIAL TURNPIKE EXTENSION. THE TOP NUMERAL ILLUSTRATED HEREIN AS "5" SHALL CHANGE TO THE LETTER "N" FOR USE ON THE NEWARK BAY - HUDSON COUNTY EXTENSION OR THE LETTER "P" FOR USE ON THE PEARL HARBOR MEMORIAL TURNPIKE EXTENSION.
- D(NJTA)10-4a IS ONLY APPROVED FOR USE ON THE NEW JERSEY TURNPIKE ON THE EASTERLY AND WESTERLY ALIGNMENTS.
- THE RAMP IDENTIFIER SIGNS SHOWN ARE EXAMPLES. THE OVERALL VERTICAL DIMENSION OF ANY RAMP IDENTIFIER SIGN MAY BE CHANGED TO ACCOMMODATE THE AMOUNT OF LEGEND NEEDED TO PROPERLY IDENTIFY THE RAMP.
- THE DELINEATOR INCORPORATED AT THE TOP OF THE TENTH-MILE MARKER IS WHITE WHEN LOCATED OFF THE RIGHT SHOULDER AND YELLOW WHEN LOCATED OFF THE LEFT SHOULDER.

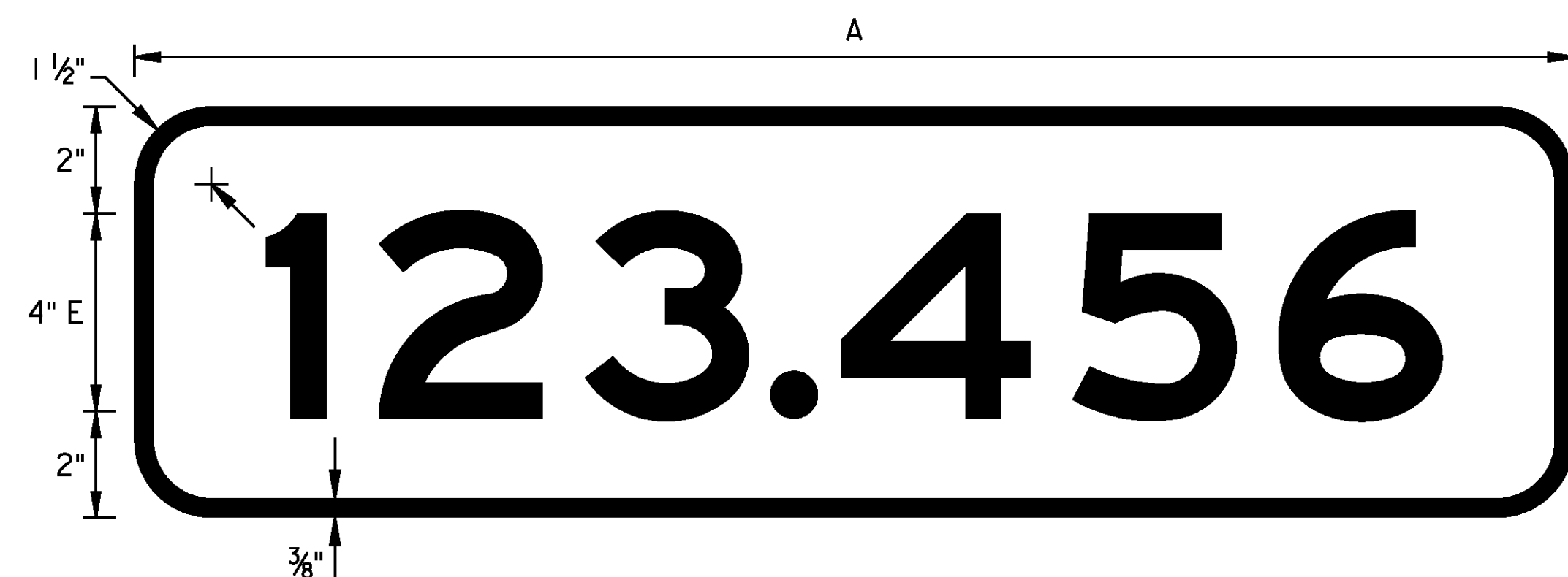

STRUCTURE IDENTIFIERS  
SEE NOTE 4

SIGN	DIGITS	A
D(NJTA)10-7a	1 - 4	21"
D(NJTA)10-7b	5	24"
D(NJTA)10-7c	6	27"
D(NJTA)10-7d	7	30"
D(NJTA)10-7e	8	33"

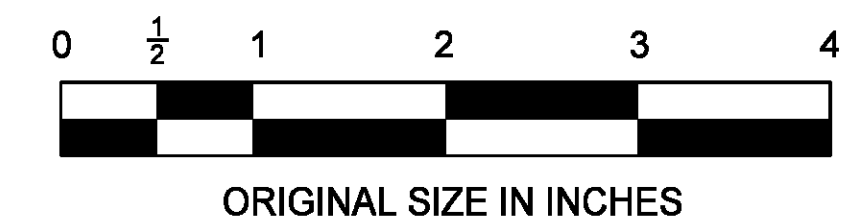

App.	No.	DATE	REVISION
		11/12	ORIGINAL DRAWING

NEW JERSEY TURNPIKE AUTHORITY

**TENTH-MILE MARKERS AND  
STRUCTURE IDENTIFIERS**

OFFICE OF THE CHIEF ENGINEER

STANDARD  
DRAWING

SL-23