

GENERAL NOTES

1. **CONCRETE:**
ALL CONCRETE SHALL BE CLASS C WITH DESIGN COMPRESSIVE STRENGTH (f'c) = 3,500 PSI
2. **TIMBER:**
(A) ALL TIMBER POSTS FOR BREAKAWAY SIGN STRUCTURES SHALL BE PRESERVATIVELY TREATED SOUTHERN YELLOW PINE GRADE NO. 2. ALL LUMBER TO BE S4S TO STANDARD SIZE UNLESS NOTED OTHERWISE.
(B) ALL SAWN TIMBER POSTS FOR NON-BREAKAWAY SIGN STRUCTURES SHALL BE PRESERVATIVELY TREATED DENSE SELECT STRUCTURAL GRADE SOUTHERN PINE. ALL LUMBER TO BE S4S TO STANDARD SIZE UNLESS NOTED OTHERWISE.
(C) ALL ROUND TIMBER POLES SHALL BE PRESERVATIVELY TREATED SOUTHERN PINE.
(D) PRESERVATIVE TREATMENT OF SAWN TIMBER POSTS SET IN THE GROUND SHALL BE IN ACCORDANCE WITH AMERICAN WOOD PRESERVERS ASSOCIATION (AWPA) STANDARDS. USE AWPA C2 AND C14 FOR SAWN TIMBER POSTS. ROUND POLES SHALL BE PRESSURE TREATED IN ACCORDANCE WITH STANDARDS C4 AND C14. ALL CUTS, ABRASIONS AND HOLES BORED AFTER TREATMENT SHALL BE LIBERALLY BRUSHED WITH THE SAME PRESERVATIVE IN ACCORDANCE WITH AWPA STANDARDS.
3. **FASTENERS:**
CARRIAGE BOLTS SHALL BE STAINLESS STEEL CONFORMING TO ASTM A320, GRADE B8 CLASS 1. ALL HARDWARE INCLUDING NAILS, SPIKES, BOLTS, NUTS, WASHERS AND LAG SCREWS SHALL BE GALVANIZED IN ACCORDANCE WITH THE APPLICABLE ASTM STANDARD SPECIFICATIONS.
4. **ALUMINUM:**
ALUMINUM ALLOY SHAPES ROLLED OR EXTRUDED ASTM B308 ALLOY 6061-T6.
5. **STEEL SLEEVES:**
STEEL SLEEVES SHALL CONFORM TO ASTM A709, GR. 36. GALVANIZE ALL STEEL SLEEVES IN ACCORDANCE WITH ASTM A123/A123M.

NOTES:

1. ALL BREAKAWAY SIGN STRUCTURES DO NOT REQUIRE ROADSIDE PROTECTION.
2. ALL NON-BREAKAWAY SIGN STRUCTURES SHALL REQUIRE ROADSIDE PROTECTION OR BE LOCATED OUTSIDE OF THE CLEAR ZONE.

REFERENCES:

1. FOR LAP JOINT, BACKING STRIP, BUTT DETAIL, BREAKAWAY HOLE, AND POST EMBEDMENT DETAILS SEE SHEET SI-46.
2. FOR SECTION D-D SEE SHEET SI-46.
3. FOR BREAKAWAY DOUBLE POST SIGN STRUCTURES SIZES AND DIMENSIONS, SEE TABLES B AND C ON SHEET SI-44.
4. FOR NON-BREAKAWAY DOUBLE AND TRIPLE POST SIGN STRUCTURES SIZES AND DIMENSIONS, SEE TABLES D THROUGH G ON SHEET SI-45.
5. FOR NON-BREAKAWAY DOUBLE AND TRIPLE POLE SUPPORTED SIGN STRUCTURES SIZES AND DIMENSIONS, SEE TABLE H ON SHEET SI-47.

TABLE A - BREAKAWAY SINGLE POST SIGN STRUCTURES

TYPE	H (FT)	W (FT)	POST SIZE	F (FT)	L (FT)	E (FT)
TYPE 1	4.0	2.5	4"x6"	7 ONLY	13.5 ONLY	3.00
TYPE 1	4.0	3.5	6"x6"	7 ONLY	14.0 ONLY	3.50
TYPE 2	5.0	3.5	6"x8"	7 ONLY	15.0 ONLY	3.50
TYPE 2	5.0	4.0	6"x8"	7 TO 9.5	15.5 TO 18.0	4.00
TYPE 3	7.0	3.5	6"x8"	7 ONLY	17.5 ONLY	4.00

ALL POSTS IN THIS TABLE REQUIRE THE BREAKAWAY HOLE DETAIL AS SHOWN ON SHEET SI-46

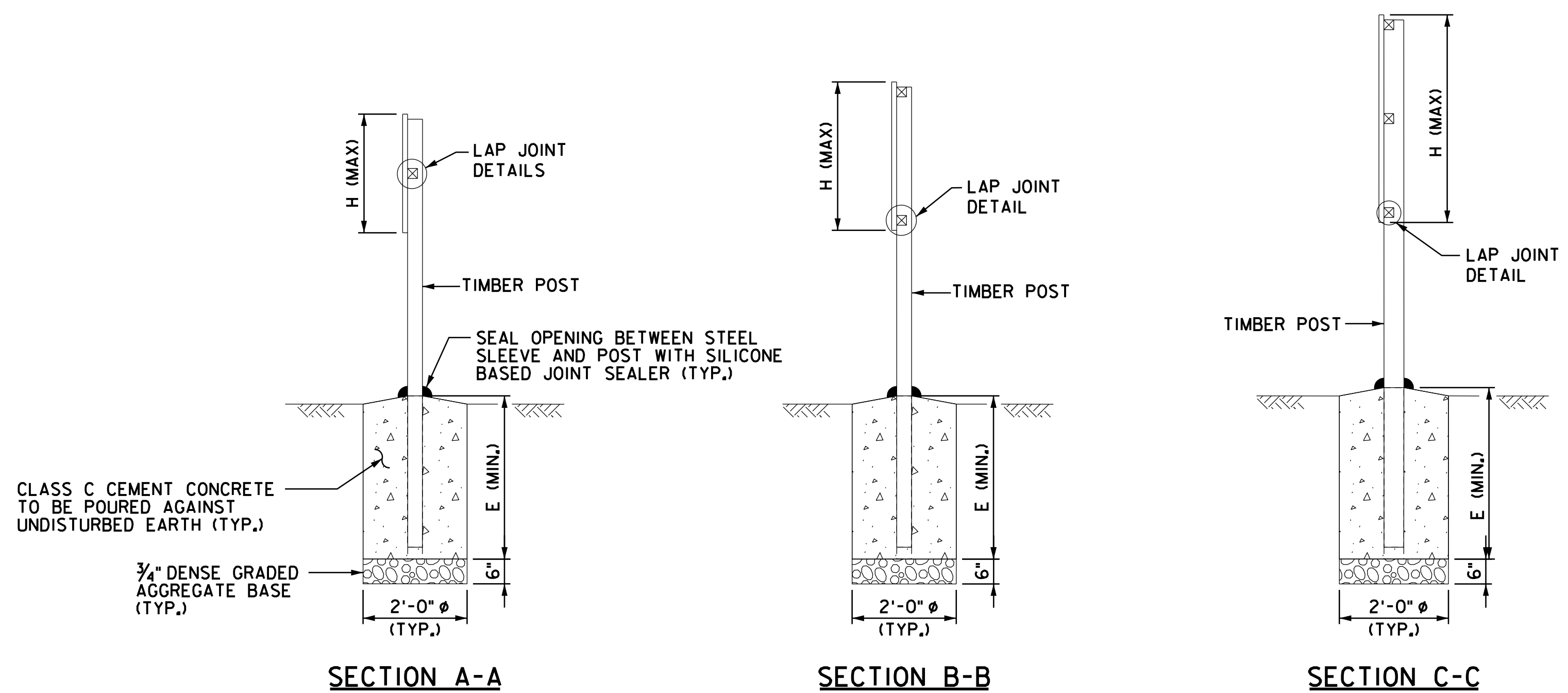

SECTION A-A

SECTION B-B

SECTION C-C

SINGLE POST SIGNS
N.T.S.

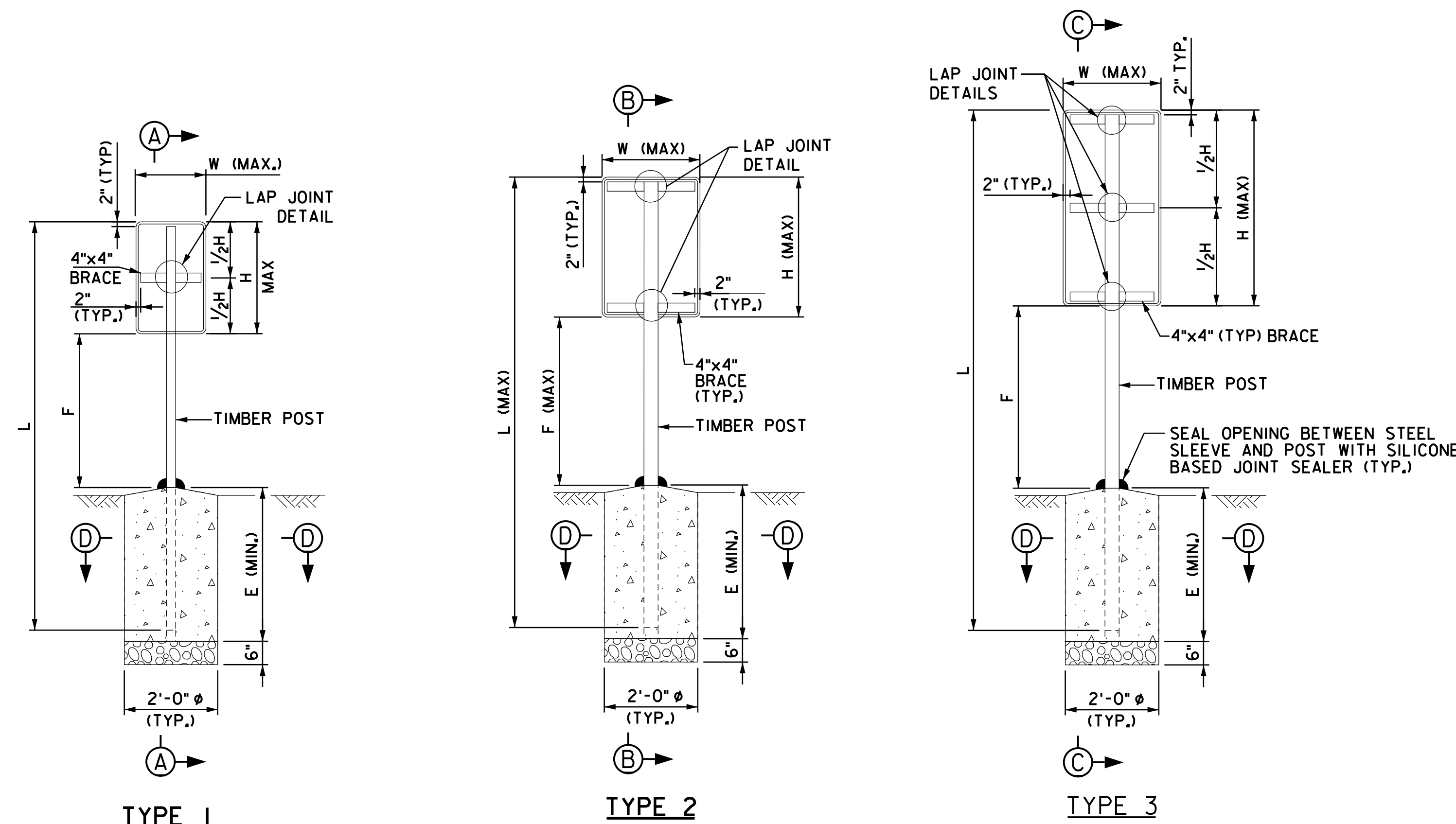

TYPE 1

TYPE 2

TYPE 3

GROUND MOUNTED SIGN STRUCTURES FOR SINGLE POST SIGNS
(REAR VIEW)
N.T.S.

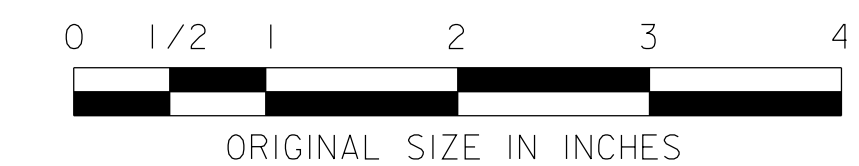

NEW JERSEY TURNPIKE AUTHORITY
NEW JERSEY TURNPIKE
GARDEN STATE PARKWAY

GROUND MOUNTED SIGNS
BREAKAWAY SINGLE POST SIGNS

OFFICE OF THE CHIEF ENGINEER
NEW JERSEY TURNPIKE AUTHORITY

STANDARD DRAWING

0	ORIGINAL DRAWING	6/16
REV.	DESCRIPTION	DATE

CONTRACT NO.

SHEET NO. OF

SI-43