

**DRUM FACE MESSAGES**

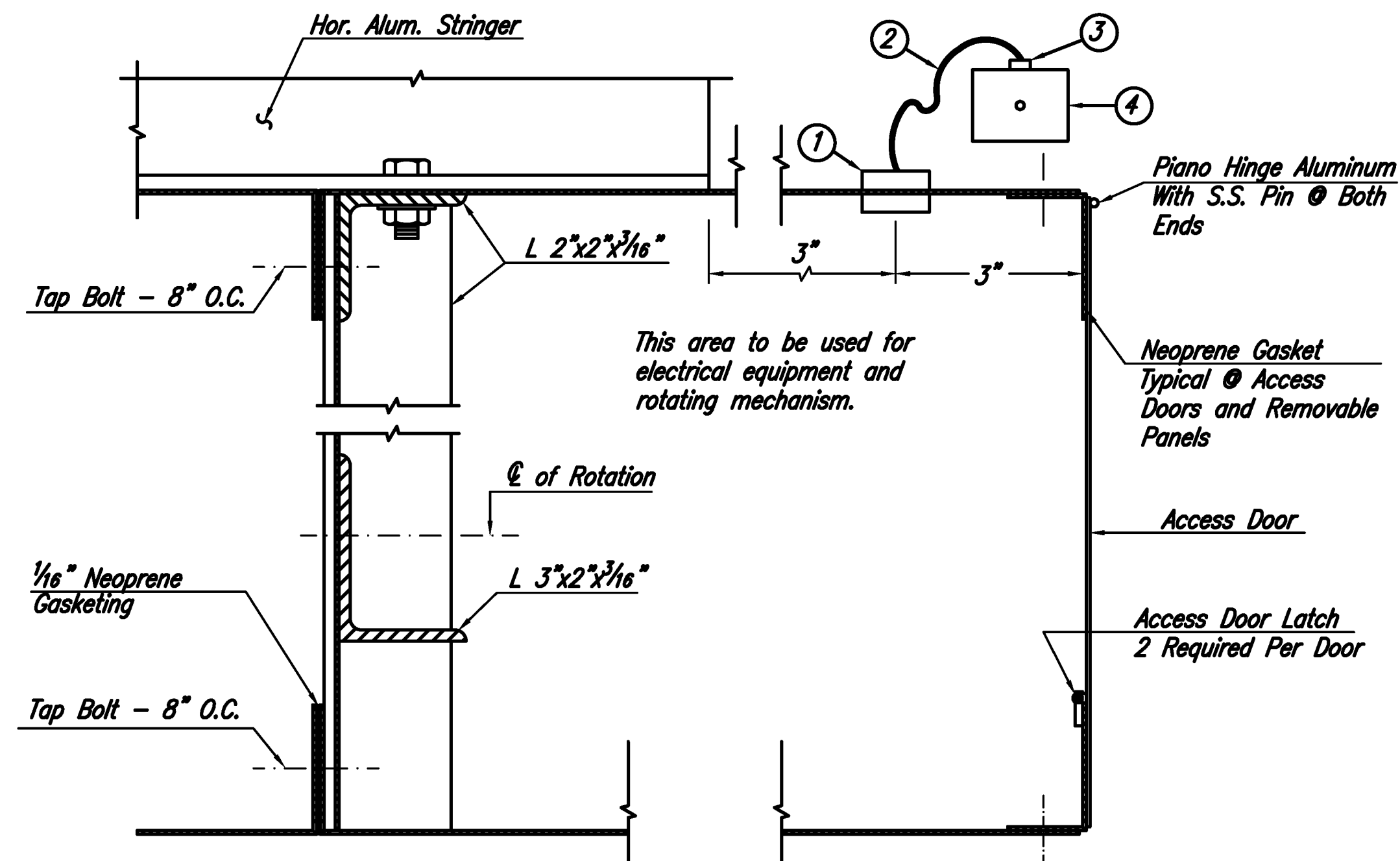

**SECTION D-D**

- ① Sealing Gland
- ② 4 Wire Tyrex Cord
- ③ 4 Wire Twist Lock Plug With Seal Tight Rubber Cover
- ④ FD Box With Twist Lock Weatherproof Receptacle

**NOTE:**  
For details of sign hanger, railing and grating installation, see Std. Dwg. SI-19 and SI-20.

**HALF ELEVATION**

**SIDE VIEW**

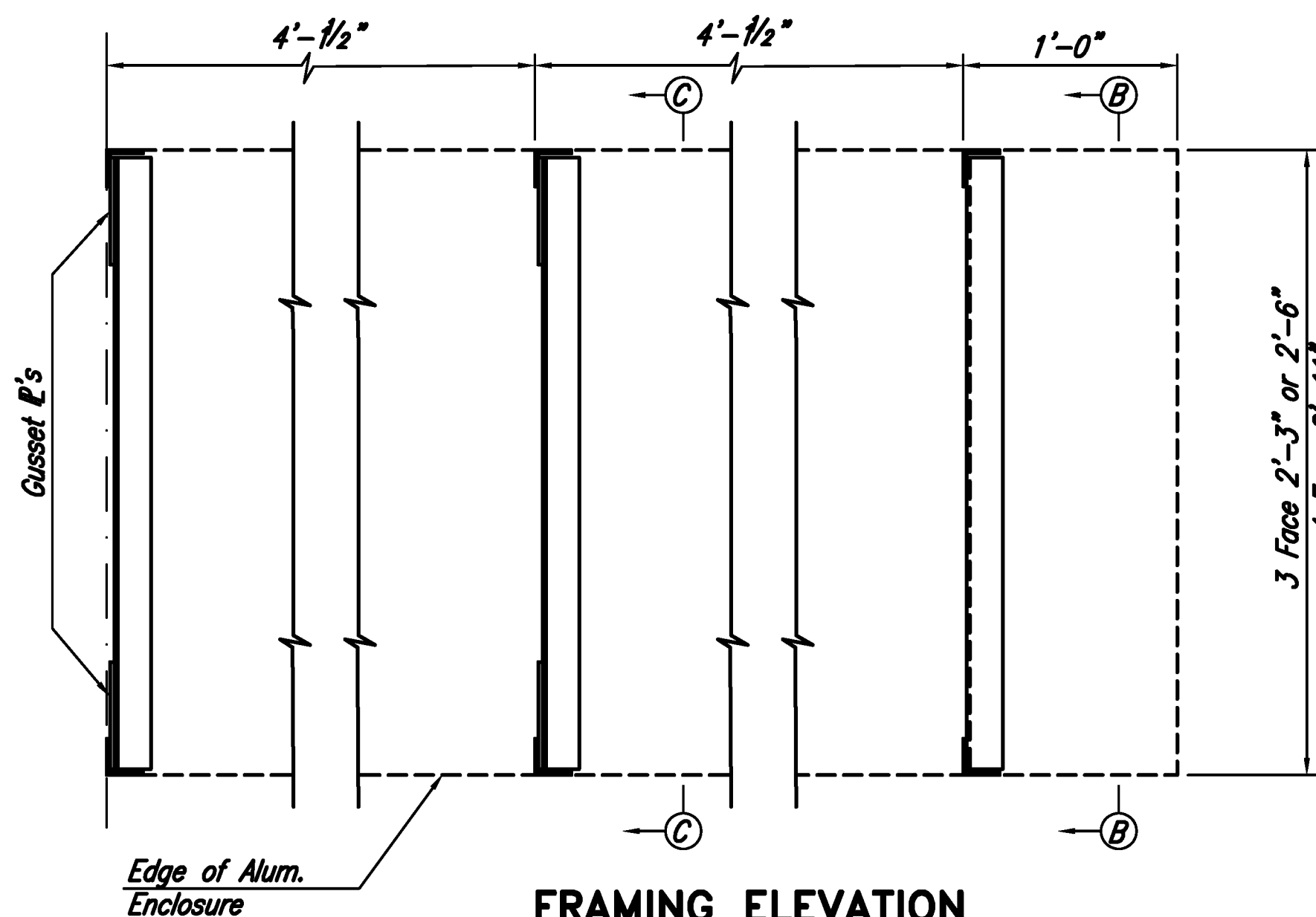

**FRAMING ELEVATION**

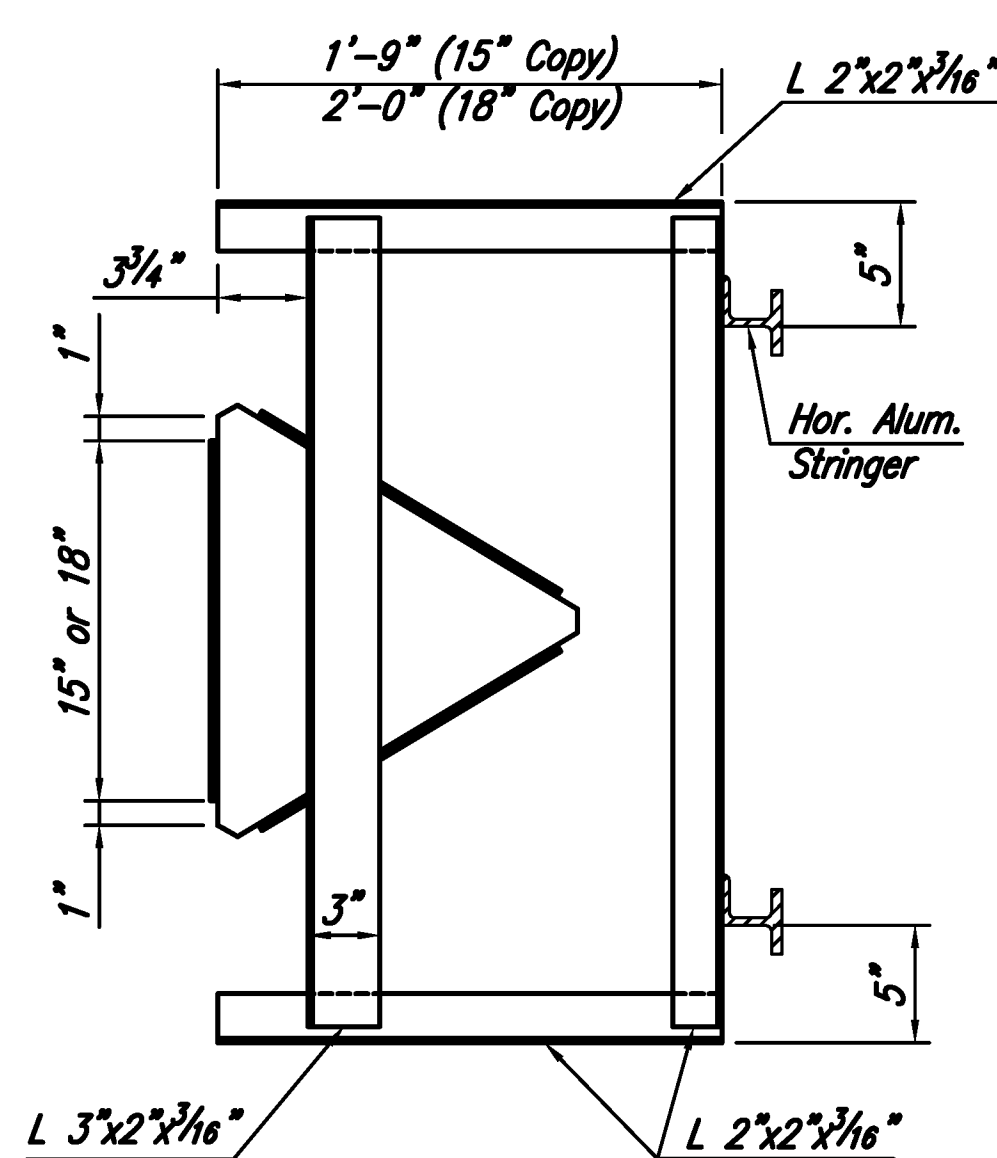

**SECTION B-B**  
(See also Section A-A)

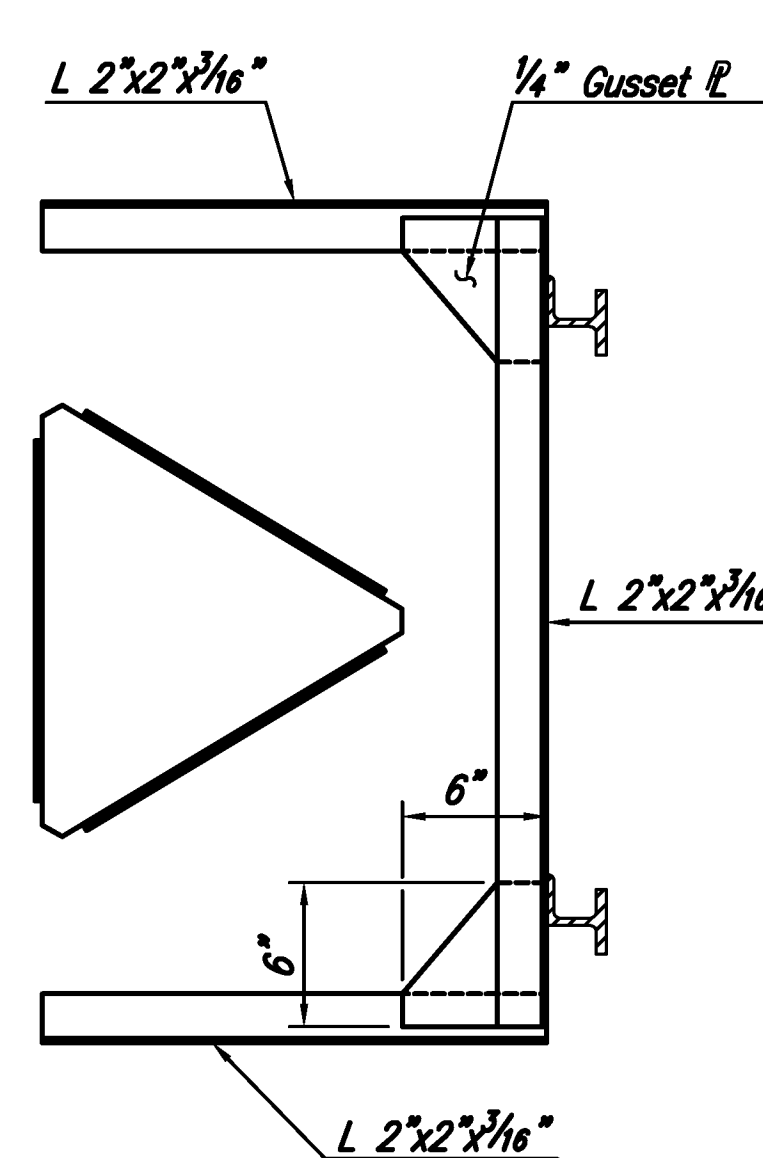

**SECTION C-C**  
(See also Section A-A)

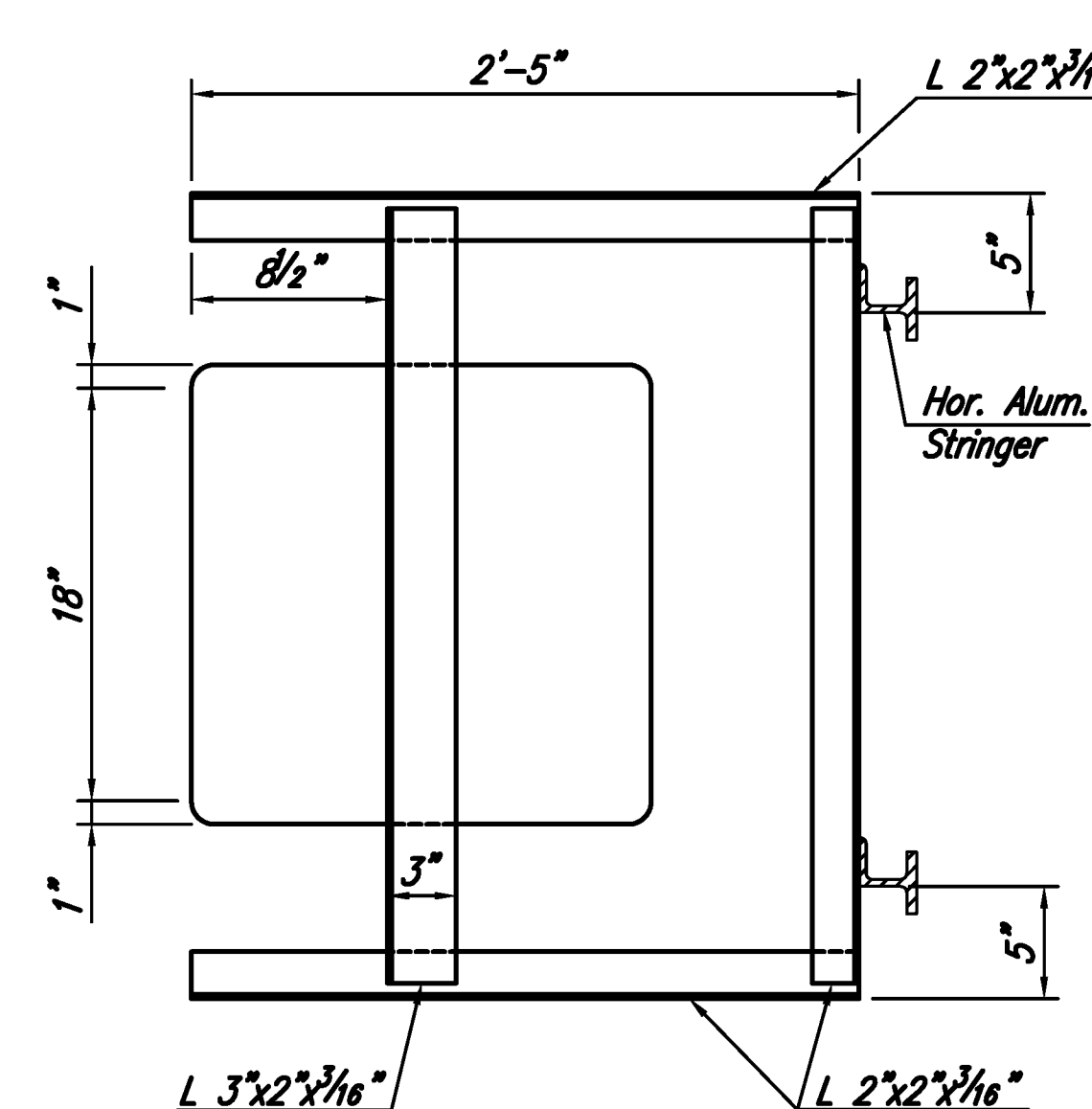

**SECTION B-B**  
(See also Section A-A)

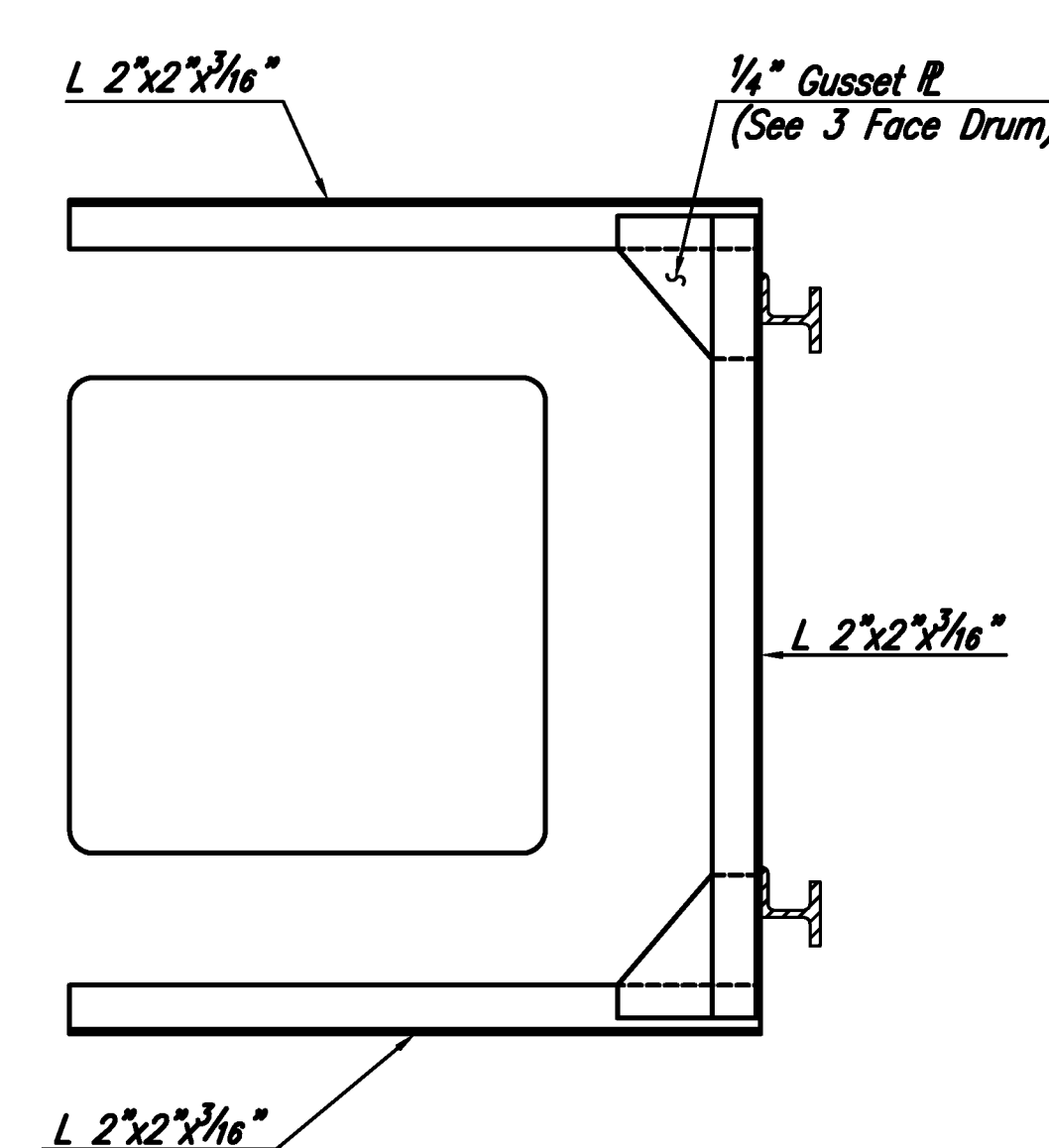

**SECTION C-C**  
(See also Section A-A)

**3 FACE DRUM**

**4 FACE DRUM**

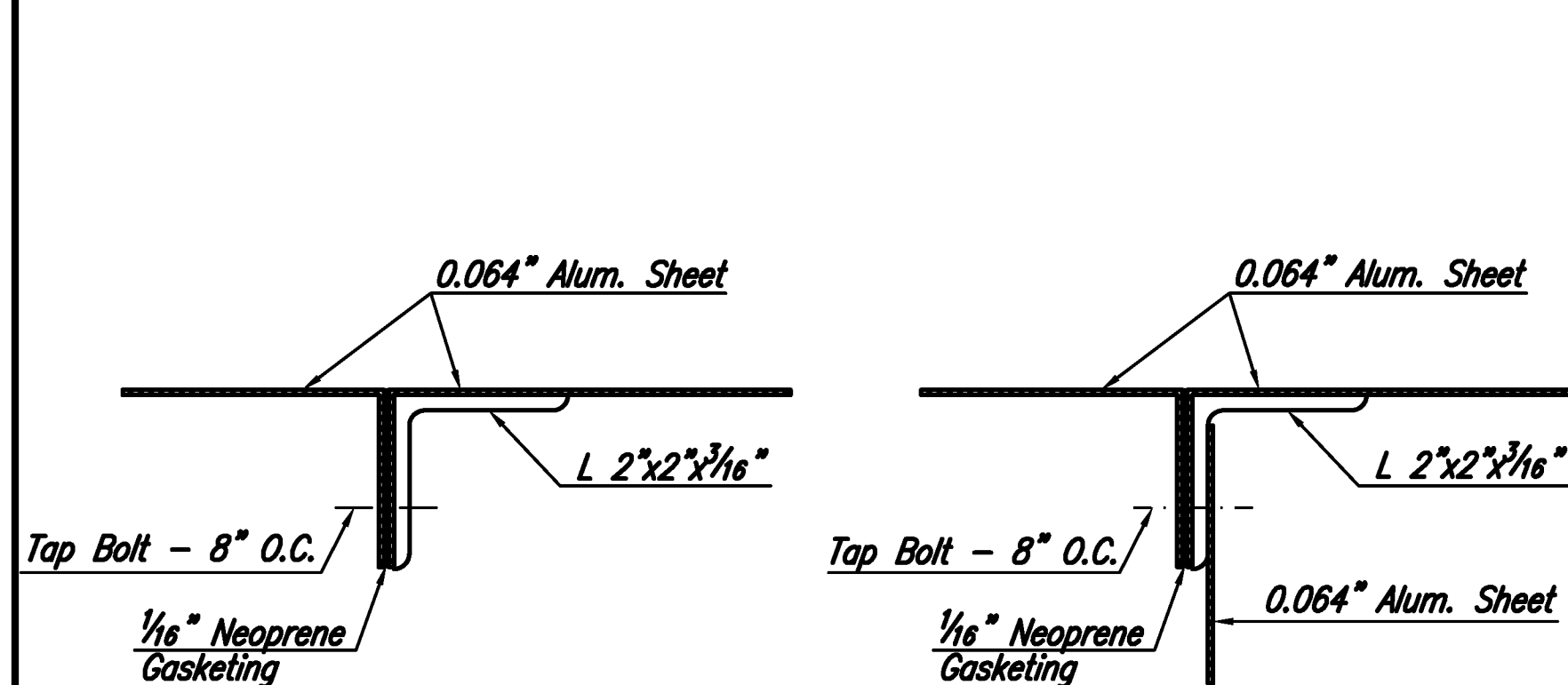

**DETAIL "A"**

**DETAIL "B"**

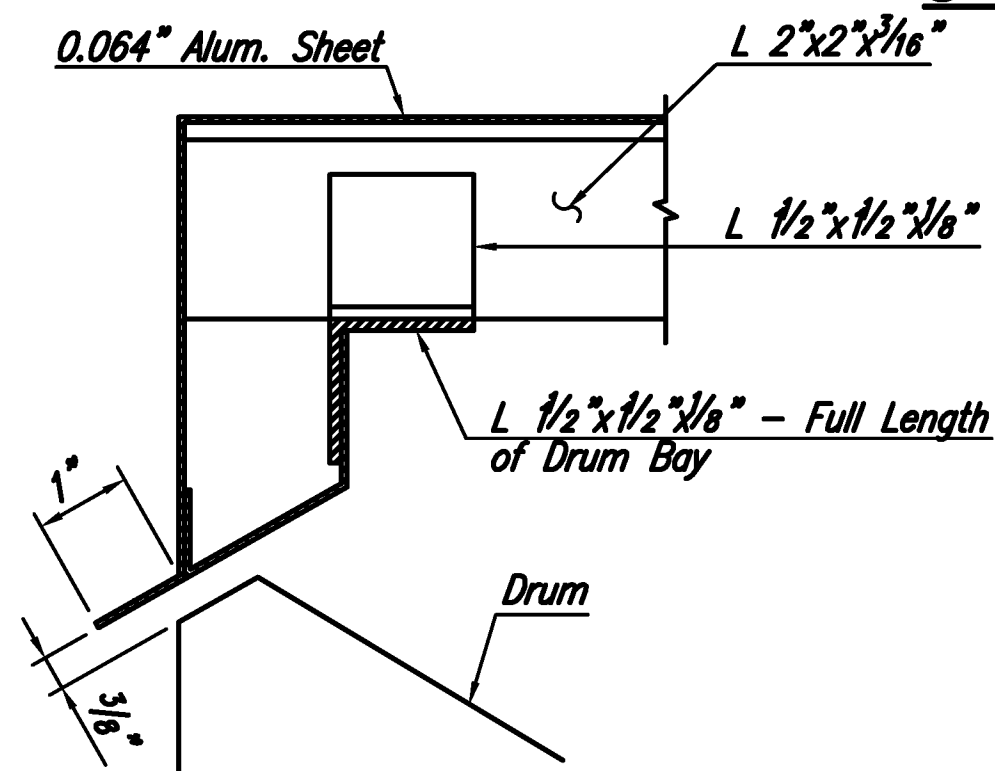

**SECTION A-A**

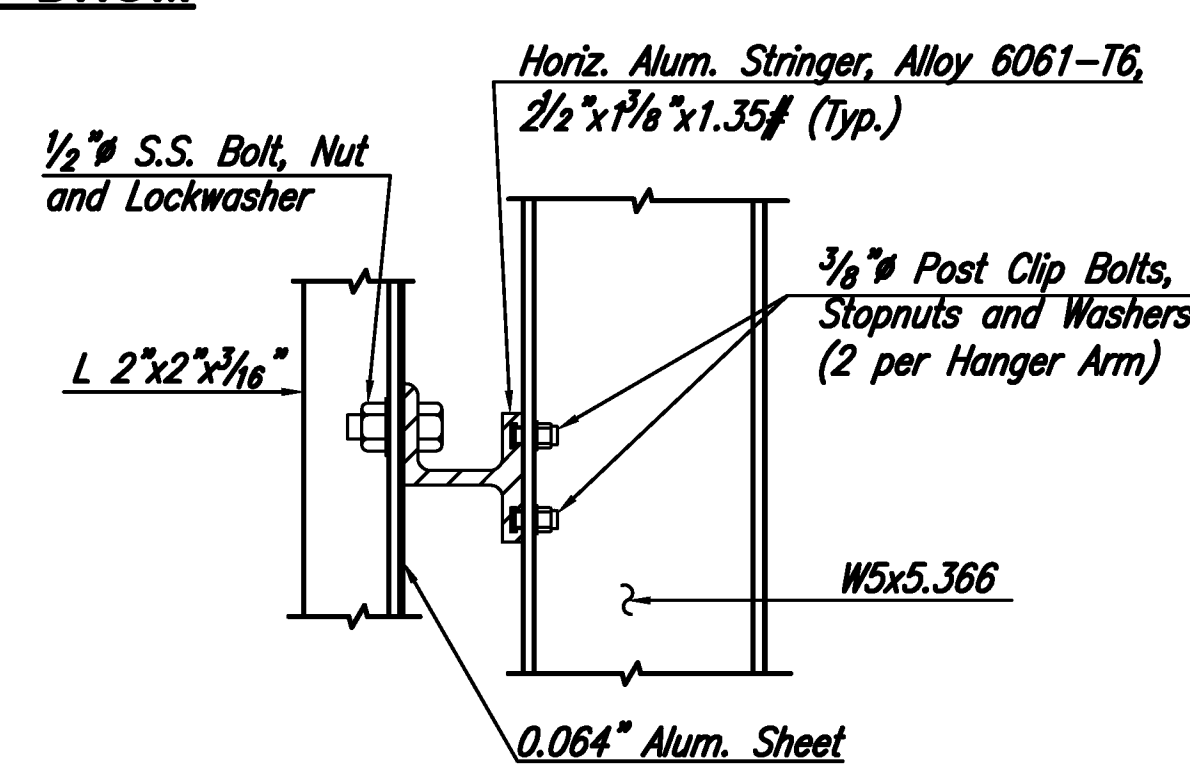

**DETAIL "C"**

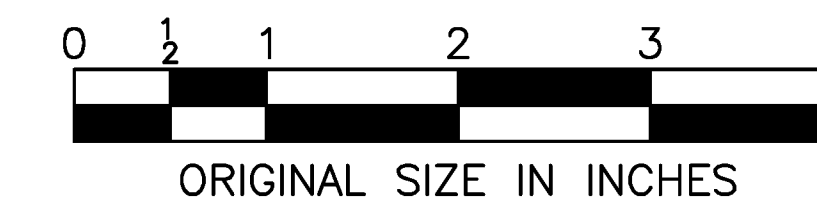

NEW JERSEY TURNPIKE AUTHORITY  
NEW JERSEY TURNPIKE

CHANGEABLE MESSAGE SIGN

OFFICE OF THE CHIEF ENGINEER  
WOODBRIIDGE, NEW JERSEY

2009 STANDARD DRAWING  
SI-25

APP. NO.	04/09	DATE
----------	-------	------

CONTRACT NO.

SHEET NO.

OF